

**TABLE: AVAILABLE OPTIONS**

POWERLOK ASSEMBLY PART NUMBER	PIPE SIZE: (NPS)	A	ØC	Ey 2X	T
PLK1120D16E1	1"	10.00	2.000	5.00	.375
PLK1120D16E2				5.50	
PLK1120D16E3				7.00	
PLK1120D16E4				8.00	
PLK1120D24E1	1-1/2"	10.00	2.500	5.00	.500
PLK1120D24E2				5.50	
PLK1120D24E3				7.00	
PLK1120D24E4				8.00	
PLK1120D32E1	2"	10.00	3.000	5.00	.500
PLK1120D32E2				5.50	
PLK1120D32E3				7.00	
PLK1120D32E4				8.00	
PLK1120D40E1	2-1/2"	10.00	3.750	5.00	.625
PLK1120D40E2				5.50	
PLK1120D40E3				7.00	
PLK1120D40E4				8.00	
PLK1120D48E1	3"	11.75	4.375	5.00	.750
PLK1120D48E2				5.50	
PLK1120D48E3				7.00	
PLK1120D48E4				8.00	
PLK1120D56E1	3-1/2"	11.75	5.000	5.00	.750
PLK1120D56E2				5.50	
PLK1120D56E3				7.00	
PLK1120D56E4				8.00	

THIS DRAWING AND THE INFORMATION CONTAINED HEREIN ARE THE PROPERTY OF DMCPower AND SHALL NOT BE COPIED, REPRODUCED OR DISCLOSED WITHOUT EXPRESS AUTHORIZATION BY DMCPower.

**TABLE: AVAILABLE OPTIONS (CON'T)**

POWERLOK ASSEMBLY PART NUMBER	PIPE SIZE: (NPS)	A	ØC	Ey 2X	T
PLK1120D64E1	4"	11.75	5.500	5.00	.750
PLK1120D64E2				5.50	
PLK1120D64E2T				5.50	
PLK1120D64E3				7.00	
PLK1120D64E4				8.00	
PLK1120D80E1	5"	14.50	6.500	5.00	1.00
PLK1120D80E2				5.50	
PLK1120D80E3				7.00	
PLK1120D80E4				8.00	
PLK1120D96E1	6"	21.15	8.000	5.00	1.25
PLK1120D96E2				5.50	
PLK1120D96E3				7.00	
PLK1120D96E4				8.00	

**LEGEND:**

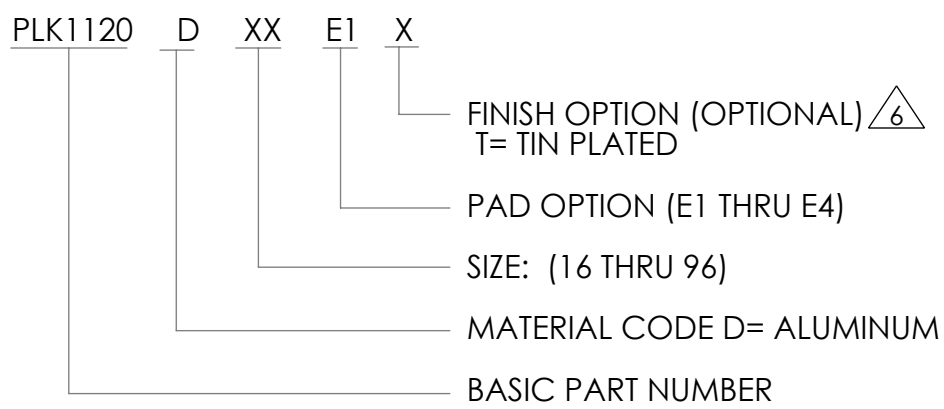

THIS DRAWING AND THE INFORMATION CONTAINED HEREIN ARE THE PROPERTY OF DMCPower AND SHALL NOT BE COPIED, REPRODUCED OR DISCLOSED WITHOUT EXPRESS AUTHORIZATION BY DMCPower.