

LEGEND

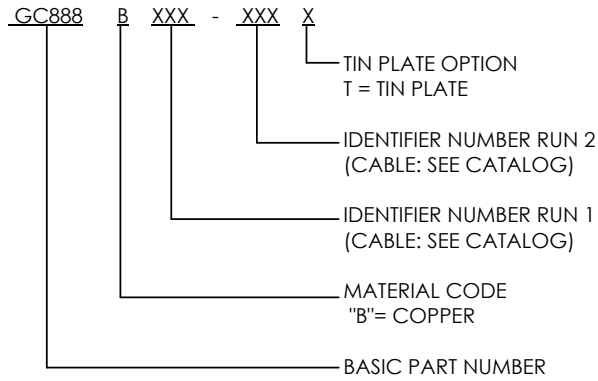

TABLE 1: OPTIONS				
ASSEMBLY	CABLE SIZE RUN 1	CABLE SIZE RUN 2	TOOLING HEAD ASSEMBLY	(Ø B)
GC888B002-002	2/0 AWG	2/0 AWG	DLT45CLHA11130	2.00
GC888B002-003	2/0 AWG	3/0 AWG	DLT45CLHA11130	
GC888B002-004	2/0 AWG	4/0 AWG	DLT45CLHA11130	
GC888B002-025	2/0 AWG	250 MCM	DLT45CLHA11130	
GC888B003-003	3/0 AWG	3/0 AWG	DLT45CLHA11130	
GC888B003-004	3/0 AWG	4/0 AWG	DLT45CLHA11130	
GC888B003-025	3/0 AWG	250 MCM	DLT45CLHA11130	
GC888B004-004	4/0 AWG	4/0 AWG	DLT45CLHA11130	
GC888B004-025	4/0 AWG	250 MCM	DLT45CLHA11130	
GC888B004-030	4/0 AWG	300 MCM	DLT45CLHA11130	
GC888B004-625	4/0 AWG	#5 REBAR	DLT45CLHA11130	
GC888B025-025	250 MCM	250 MCM	DLT45CLHA11130	
GC888B562-562	5/8" COPPER CLAD	5/8" COPPER CLAD	DLT45CLHA11130	

THIS DRAWING AND THE INFORMATION CONTAINED HEREIN ARE THE PROPERTY OF DMC POWER AND SHALL NOT BE COPIED, REPRODUCED OR DISCLOSED WITHOUT EXPRESS AUTHORIZATION BY DMC POWER.