

# DMCPOWER

Next Generation Power Connections

## BUS CONNECTORS

STANDARD & EHV TO 765 KV



# BUS CONNECTOR SYSTEM

## Faster, More Reliable Bus Installations

If installation speed, quality, safety and total project cost is important on your job site, stop welding and start Swaging.

Extensive comparative testing shows the DMC Power Swaging system outperforms welded and bolted counterparts in all major tests. Each Swaged Bus connector results in a superior mechanical, thermal and electrical connection for your substation needs.

Qualified to meet or exceed all the nationally recognized standards, including ANSI C119.4 and NEMA CC1, the DMC Power system raises the quality, safety and productivity standard on your site, rendering conventional methods obsolete.

### Putting DMC Power to the Test\*

Corona/RIV .....Qualified for up to 750kV substations\*\*  
Fault Current.....45kA  
Current Cycle.....500 cycles air, 100 cycles water  
Bending .....13,000 lbs. load  
Vibration .....2hz to 125hz, over 1 million cycles  
Tensile .....Over 17,000 lbs.  
Salt Fog .....1,000 hours per ASTM B117-90

\* Typical results for 2 inch bus fittings

\*\* Some parts may require additional shielding

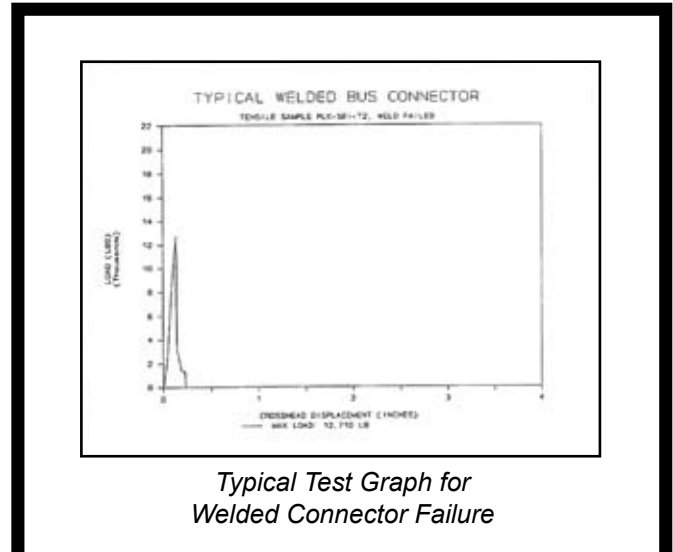

Typical Test Graph for Welded Connector Failure

## THE PROOF IS IN THE TESTING

Swaged connections carry a greater load for a longer amount of time versus welding.

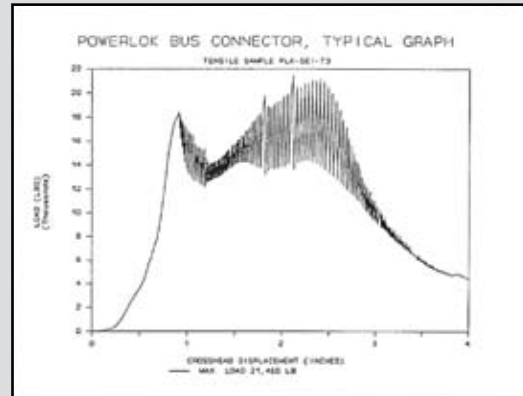

Typical Test Graph for DMC Power Swaged Connector



Current Cycle Testing



Temperature Rise Testing



Bend Testing

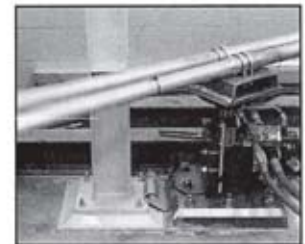

Vibration Testing

# STANDARD PRODUCT DIMENSIONS

- The following information and dimensional data is consistent throughout the DMC Power product line
- All dimensions are standard sizes and listed in inches (metric available)
- Contact DMC Power for information on custom fittings that can be designed to fit your specifications

## STANDARD DMC POWER CONFIGURATION

These dimensions are consistent throughout this product line and will not be repeated in each table.

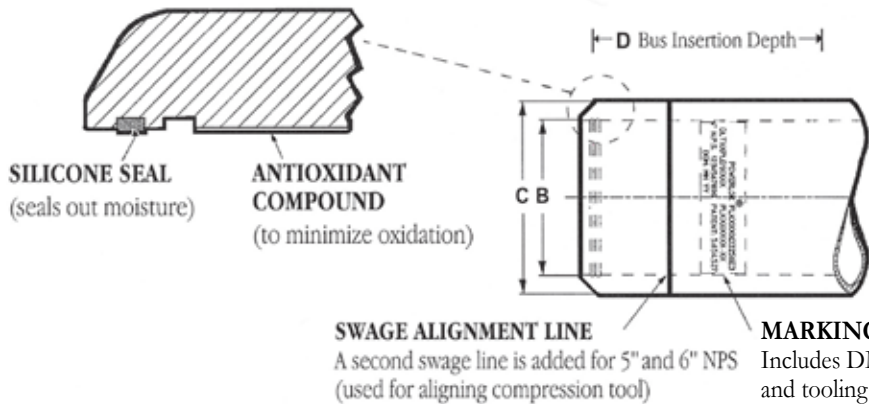

DMC Size	Bus Size	C Dia (O.D.)	D Min.	D Max
16	1"	2.00	1.50	2.00
24	1-1/2"	2.50	1.50	2.00
32	2"	3.00	2.00	2.50
40	2-1/2"	3.75	2.00	2.50
48	3"	4.37	3.00	3.50
56	3-1/2"	5.00	3.00	3.50
64	4"	5.50	3.00	3.50
80	5"	6.50	5.00	5.75
96	6"	8.00	6.00	6.75

## STANDARD NEMA PAD CONFIGURATIONS

Diagrams below are standard dimensions but customization is available for all parts, contact DMC Power for details. Pad thickness is dependant on Bus size.

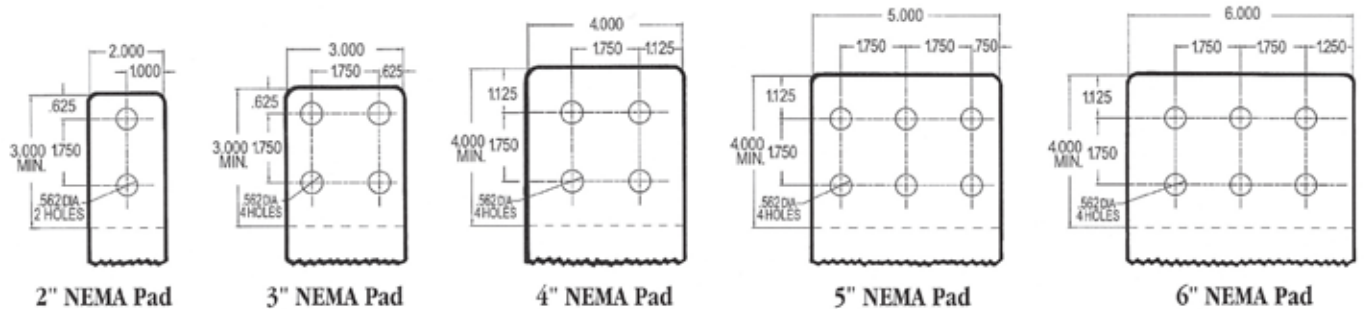

## STANDARD BOLT CIRCLE CONFIGURATIONS

Diagrams below are standard dimensions, contact DMC Power for customization options.

### E1, E2, or E3

8 curved slots (S Holes) on a "B" diameter circle

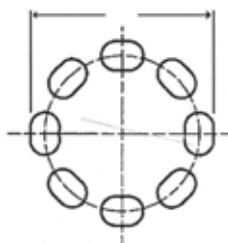

Suffix	Hole Diameter	Hole Size	Plate Thickness
E1	3"	8: 9/16" x 13/16"	1/2"
E2	5"	8: 11/16" x 1-1/16"	1/2"
E3	7"	8: 13/16" x 1-1/2"	1/2"
E12	3" & 5"	16: 9/16" x 13/16" 11/16" x 1-1/16"	3/4"
E23	5" & 7"	16: 11/16" x 1-1/16" 13/16" x 1-1/2"	3/4"

**E12 & E23** hole patterns, 16 slots total  
Thickness of E12 & E23 bolt circle plates is 3/4"

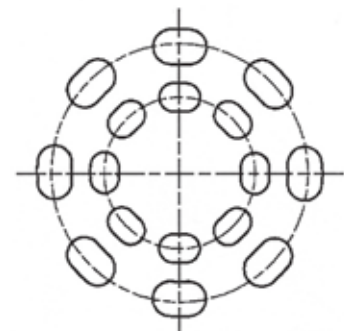



# BUS CONNECTORS

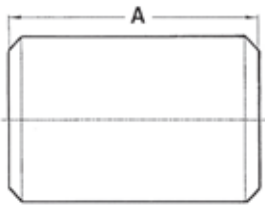

## Bus to Bus Splice

PART NO.	SIZE NPS	A
PLK1000D16	1	6.00
PLK1000D24	1-1/2	6.00
PLK1000D32	2	6.00
PLK1000D40	2-1/2	6.00
PLK1000D48	3	7.25
PLK1000D56	3-1/2	8.25
PLK1000D64	4	9.25
PLK1000D80	5	13.00
PLK1000D96	6	15.00

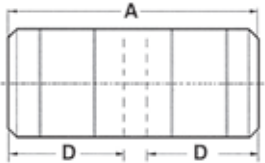

## Bus to Bus Long Splice Double Swage

PART NO.	SIZE NPS	A	D MIN.	D MAX.
PLK1001D16	1	10.00	4.38	4.88
PLK1001D24	1-1/2	10.00	4.38	4.88
PLK1001D32	2	10.00	4.38	4.88
PLK1001D40	2-1/2	10.00	4.38	4.88
PLK1001D48	3	11.75	5.38	5.88
PLK1001D56	3-1/2	11.75	5.38	5.88
PLK1001D64	4	11.75	5.38	5.88
PLK1001D80	5	17.00	7.88	8.38
PLK1001D96	6	19.00	8.88	9.38

D - Bus insertion depth is not standard

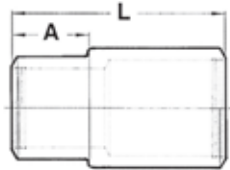

## Reducer Splice

PART NO.	1st END SIZE NPS	2nd END SIZE NPS	A	L
PLK1010D1624	1	1-1/2	2.50	7.00
PLK1010D2432	1-1/2	2	2.75	7.25
PLK1010D3240	2	2-1/2	3.00	7.75
PLK1010D4048	2-1/2	3	3.25	8.25
PLK1010D4856	3	3-1/2	3.50	8.75
PLK1010D5664	3-1/2	4	3.50	8.75
PLK1010D6480	4	5	3.25	11.75

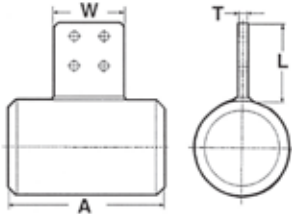

## Bus to 4-Hole NEMA Pad

PART NO.	SIZE NPS	A	T
PLK1100D16Ey	1	10.00	.375
PLK1100D24Ey	1-1/2	10.00	.500
PLK1100D32Ey	2	10.00	.500
PLK1100D40Ey	2-1/2	10.00	.625
PLK1100D48Ey	3	11.75	.750
PLK1100D56Ey	3-1/2	11.75	.750
PLK1100D64Ey	4	11.75	.750
PLK1100D80Ey	5	14.50	1.000
PLK1100D96Ey	6	16.50	1.000

	Ey	E1	E2	E3	E4	E5	E6	E7	E8
W	4.00	4.00	4.00	4.00	3.00	3.00	3.00	3.00	3.00
L	4.50	5.50	7.00	8.00	4.50	5.50	7.00	8.00	

EXAMPLE: **PLK1100D32E5** is for 2" NPS tubing with a pad 3" wide and 4.5" long  
Split-Bus to 4-Hole NEMA Pad - substitute 5100 for 1100

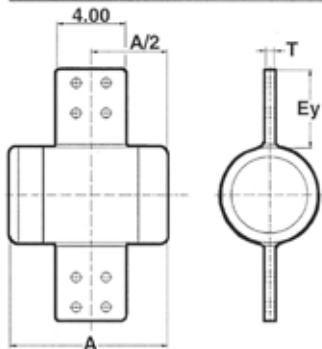

## Bus to Double Longitudinal 4-Hole NEMA Pads

PART NO.	SIZE NPS	A	T
PLK1120D16Ey	1	10.00	.375
PLK1120D24Ey	1-1/2	10.00	.500
PLK1120D32Ey	2	10.00	.500
PLK1120D40Ey	2-1/2	10.00	.625
PLK1120D48Ey	3	11.75	.750
PLK1120D56Ey	3-1/2	11.75	.750
PLK1120D64Ey	4	11.75	.750
PLK1120D80Ey	5	14.50	1.000

	Ey	E1	E2	E3	E4
dim	4.50	5.50	7.00	8.00	

Split-Bus to Double L. NEMA Pad - substitute 5120 for 1120

## Split Fittings

**NOW AVAILABLE**



For many of our parts, we now offer the "split fitting" option, where the main run is separable, making it easy to tap into existing bus structures.

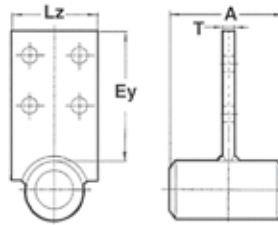

## Bus to Transverse 4-Hole NEMA Pad

PART NO.	SIZE NPS	A	T
PLK1150D16LzEy	1	6.00	.375
PLK1150D24LzEy	1-1/2	6.00	.500
PLK1150D32LzEy	2	6.00	.500
PLK1150D40LzEy	2-1/2	6.00	.625
PLK1150D48LzEy	3	7.25	.750
PLK1150D56LzEy	3-1/2	8.25	.750
PLK1150D64LzEy	4	9.25	.750
PLK1150D80LzEy	5	13.00	1.000

	Ey	E1	E2	E3	E4
dim	4.50	5.50	7.00	8.00	
	Lz	L1	L2		
dim	3.00	4.00			

Split-Bus to Transverse NEMA Pad - substitute 5150 for 1150

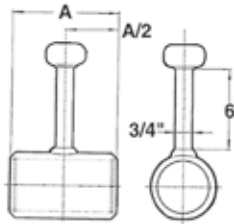

## Grounding Stud

PART NO.	SIZE NPS	A
PLK1160D16	1	6.00
PLK1160D24	1-1/2	6.00
PLK1160D32	2	6.00
PLK1160D40	2-1/2	6.00
PLK1160D48	3	7.25
PLK1160D56	3-1/2	8.25
PLK1160D64	4	9.25
PLK1160D80	5	13.00
PLK1160D96	6	15.00

Split-Grounding Stud - substitute 5160 for 1160

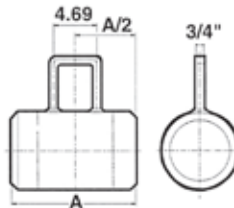

## Grounding Stirrup

PART NO.	SIZE NPS	A
PLK1161D16	1	10.00
PLK1161D24	1-1/2	10.00
PLK1161D32	2	10.00
PLK1161D40	2-1/2	10.00
PLK1161D48	3	11.75
PLK1161D56	3-1/2	11.75
PLK1161D64	4	11.75
PLK1161D80	5	14.50

Split-Grounding Stirrup - substitute 5161 for 1161

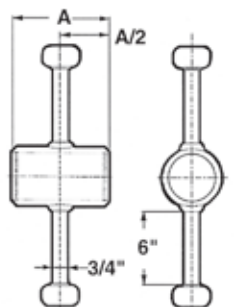

## Double Sided Grounding Stud

PART NO.	SIZE NPS	A
PLK1165D16	1	6.00
PLK1165D24	1-1/2	6.00
PLK1165D32	2	6.00
PLK1165D40	2-1/2	6.00
PLK1165D48	3	7.25
PLK1165D56	3-1/2	8.25
PLK1165D64	4	9.25
PLK1165D80	5	13.00

Split-Double Grounding Stud - substitute 5165 for 1165

# BUS CONNECTORS

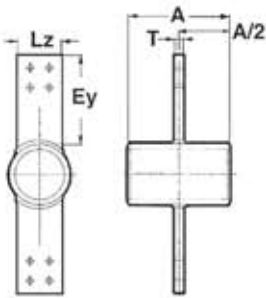

## Bus to Double Transverse 4-Hole NEMA Pads

PART NO.	SIZE NPS	A	T
PLK1170D16LzEy	1	6.00	.375
PLK1170D24LzEy	1-1/2	6.00	.500
PLK1170D32LzEy	2	6.00	.500
PLK1170D40LzEy	2-1/2	6.00	.625
PLK1170D48LzEy	3	7.25	.750
PLK1170D56LzEy	3-1/2	8.25	.750
PLK1170D64LzEy	4	9.25	.750
PLK1170D80LzEy	5	13.00	1.000

Ey dim	E1	E2	E3	E4
	4.50	5.50	7.00	8.00

Lz dim	L1	L2
	3.00	4.00

Split-Bus to Double Transverse NEMA Pad - substitute 5170 for 1170

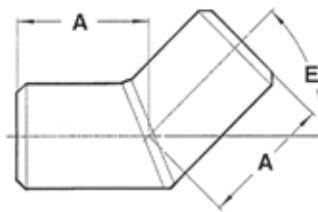

## Elbow

PART NO.	SIZE NPS	A
PLK1400D16Ey	1	4.92
PLK1400D24Ey	1-1/2	4.92
PLK1400D32Ey	2	4.92
PLK1400D40Ey	2-1/2	4.92
PLK1400D48Ey	3	5.92
PLK1400D56Ey	3-1/2	5.92
PLK1400D64Ey	4	5.92
PLK1400D80Ey	5	8.42
PLK1400D96Ey	6	9.42

A This dimension changes based upon the angle of the elbow

Ey ANGLE	E1	E2	E3	E4
	30°	45°	60°	90°

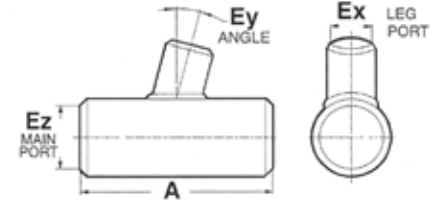

## Tee PART NUMBER $PLK1500 + D + Ex + Ez + Ey$

- where **PLK1500** is the **Basic Part Number** for all Tees
- D** is the **Material Code**, D is for Aluminum
- Ex** is the **Part Number Code for Leg Port Size**
- Ez** is the **Part Number Code for Main Run Size**
- Ey** is the **Part Number Code for Leg Angle**

Ex AND Ez	Size NPS	1	1-1/2	2	2-1/2	3	3-1/2	4	5	6
	Part # Code	16	24	32	40	48	56	64	80	96

Ey ANGLE	E1	E2	E3	E4
	0°	15°	30°	45°

EXAMPLE: **PLK1500D4864E2**

is a tee with a 3" leg, a 4" main run and a 15° angle.

**A** Overall length dimension varies from 8.5" to 24" based upon the bus size and angle.

Split-Tee - substitute 5500 for 1500

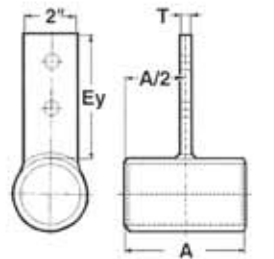

## Bus to Transverse 2-Hole NEMA Pad

PART NO.	SIZE NPS	A	T
PLK1250D16Ey	1	6.00	.375
PLK1250D24Ey	1-1/2	6.00	.500
PLK1250D32Ey	2	6.00	.500
PLK1250D40Ey	2-1/2	6.00	.625
PLK1250D48Ey	3	7.25	.750
PLK1250D56Ey	3-1/2	8.25	.750
PLK1250D64Ey	4	9.25	.750
PLK1250D80Ey	5	13.00	1.000

Ey dim	E1	E2	E3	E4
	5.50	6.50	8.00	9.00

Split-Bus to Transverse 2-Hole NEMA Pad - substitute 5250 for 1250

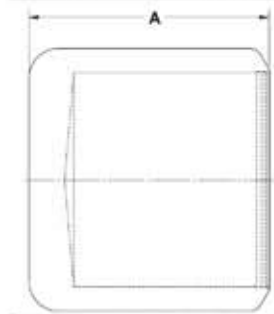

## End Cap

PART NO.	SIZE NPS	A
PLK1350D16	1	3.000
PLK1350D24	1-1/2	3.000
PLK1350D32	2	3.500
PLK1350D40	2-1/2	3.500
PLK1350D48	3	4.000
PLK1350D56	3-1/2	4.000
PLK1350D64	4	4.000
PLK1350D80	5	6.438
PLK1350D96	6	6.438

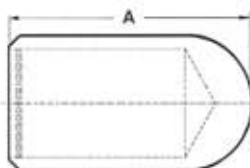

## Rounded End Cap

PART NO.	SIZE NPS	A
PLK1360D16	1	3.50
PLK1360D24	1-1/2	3.75
PLK1360D32	2	4.95
PLK1360D40	2-1/2	5.32
PLK1360D48	3	5.70
PLK1360D56	3-1/2	6.00
PLK1360D64	4	6.25
PLK1360D80	5	8.25
PLK1360D96	6	9.25

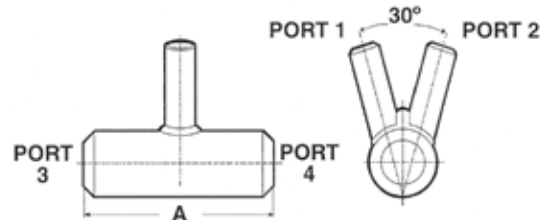

## A Frame

PART NO.	PORT 1 & 2	PORT 3 & 4	A
PLK1600D1632	1	2	10.00
PLK1600D1640	1	2-1/2	10.00
PLK1600D1648	1	3	11.75
PLK1600D1656	1	3-1/2	11.75
PLK1600D1664	1	4	11.75
PLK1600D2440	1-1/2	2-1/2	10.00
PLK1600D2448	1-1/2	3	11.75
PLK1600D2456	1-1/2	3-1/2	11.75
PLK1600D2464	1-1/2	4	11.75
PLK1600D3248	2	3	11.75
PLK1600D3256	2	3-1/2	11.75

PART NO.	PORT 1 & 2	PORT 3 & 4	A
PLK1600D3264	2	4	11.75
PLK1600D3280	2	5	11.75
PLK1600D4056	2-1/2	3-1/2	11.75
PLK1600D4064	2-1/2	4	11.75
PLK1600D4080	2-1/2	5	17.00
PLK1600D4864	3	4	11.75
PLK1600D4880	3	5	17.00
PLK1600D5680	3-1/2	5	17.00
PLK1600D4896	3	6	15.00
PLK1600D5696	3-1/2	6	19.00
PLK1600D6496	4	6	19.00

Split-A Frame - substitute 5600 for 1600

# BUS CONNECTORS

## A Frame - Wider Body to Accommodate Larger Legs

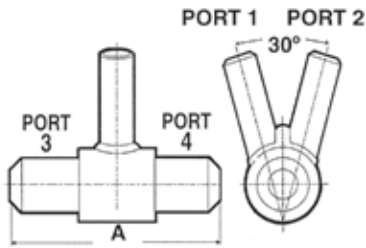

PART NO.	PORT 1 & 2	PORT 3 & 4	A
PLK1650D1616	1	1	9.50
PLK1650D1624	1	1-1/2	10.00
PLK1650D2424	1-1/2	1-1/2	10.00
PLK1650D2432	1-1/2	2	10.50
PLK1650D3232	2	2	10.50
PLK1650D3240	2	2-1/2	11.25
PLK1650D4040	2-1/2	2-1/2	11.25
PLK1650D4048	2-1/2	3	11.75
PLK1650D4848	3	3	11.75
PLK1650D5656	3-1/2	3-1/2	11.75
PLK1650D6480	4	5	18.00
PLK1650D8096	5	6	19.00

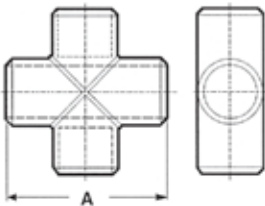

### Cross

PART NO.	SIZE NPS	A
PLK1700D16	1	8.50
PLK1700D24	1-1/2	8.50
PLK1700D32	2	8.50
PLK1700D40	2-1/2	10.00
PLK1700D48	3	11.75
PLK1700D56	3-1/2	11.75
PLK1700D64	4	11.75
PLK1700D80	5	17.00

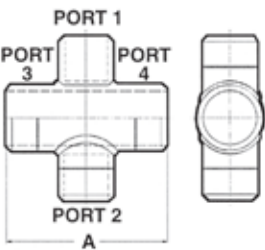

### Dual Size Cross

PART NO.	TABS NPS PORTS 1 & 2	MAIN RUN PORTS 3 & 4	A
PLK1701D1632	1	2	8.50
PLK1701D2432	1-1/2	2	8.50
PLK1701D2440	1-1/2	2-1/2	8.50
PLK1701D3248	2	3	8.50
PLK1701D4048	2-1/2	3	8.50
PLK1701D4864	3	4	8.50
PLK1701D5664	3-1/2	4	8.50
PLK1701D6480	4	5	14.50

Split-Dual Size Cross - substitute 5701 for 1701 for split along Main Run

## 4-Hole Terminal NEMA Pad Center Formed

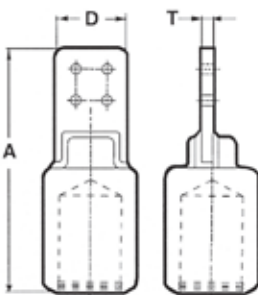

PART NO.	SIZE NPS	A	D	T
PLK1850D16A	1	8.25	3.00	.375
PLK1850D16B	1	8.25	4.00	.375
PLK1850D24A	1-1/2	8.50	3.00	.500
PLK1850D24B	1-1/2	8.50	4.00	.500
PLK1850D32A	2	9.65	3.00	.500
PLK1850D32B	2	9.65	4.00	.500
PLK1850D40A	2-1/2	10.02	3.00	.625
PLK1850D40B	2-1/2	10.02	4.00	.625
PLK1850D48A	3	10.20	3.00	.750
PLK1850D48B	3	10.20	4.00	.750
PLK1850D56A	3-1/2	10.50	3.00	.750
PLK1850D56B	3-1/2	10.50	4.00	.750
PLK1850D64A	4	10.75	3.00	.750
PLK1850D64B	4	10.75	4.00	.750
PLK1850D80A	5	11.75	3.00	1.000
PLK1850D80B	5	11.75	4.00	1.000
PLK1850D96A	6	12.75	3.00	1.000
PLK1850D96B	6	12.75	4.00	1.000

## 2-Hole Terminal NEMA Pad Center Formed

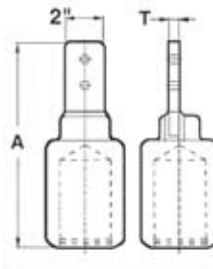

PART NO.	SIZE NPS	A	T
PLK1855D16	1	8.25	.375
PLK1855D24	1-1/2	8.50	.500
PLK1855D32	2	9.65	.500
PLK1855D40	2-1/2	10.02	.625
PLK1855D48	3	10.20	.750
PLK1855D56	3-1/2	10.50	.750
PLK1855D64	4	10.75	.750
PLK1855D80	5	12.75	1.000

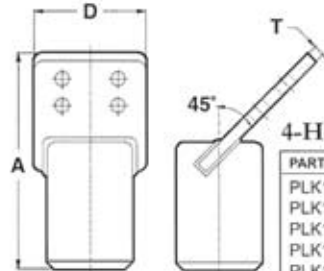

## 4-Hole Terminal 45° NEMA Pad

PART NO.	SIZE NPS	A	D	T
PLK1860D16A	1	8.43	3.00	.375
PLK1860D16B	1	8.43	4.00	.375
PLK1860D24A	1-1/2	8.70	3.00	.500
PLK1860D24B	1-1/2	8.70	4.00	.500
PLK1860D32A	2	10.00	3.00	.500
PLK1860D32B	2	10.00	4.00	.500
PLK1860D40A	2-1/2	10.23	3.00	.625
PLK1860D40B	2-1/2	10.23	4.00	.625
PLK1860D48A	3	10.56	3.00	.750
PLK1860D48B	3	10.56	4.00	.750
PLK1860D56A	3-1/2	10.71	3.00	.750
PLK1860D56B	3-1/2	10.71	4.00	.750
PLK1860D64A	4	10.86	3.00	.750
PLK1860D64B	4	10.86	4.00	.750
PLK1860D80A	5	12.40	3.00	1.000
PLK1860D80B	5	12.40	4.00	1.000
PLK1860D96A	6	13.40	3.00	1.000
PLK1860D96B	6	13.40	4.00	1.000

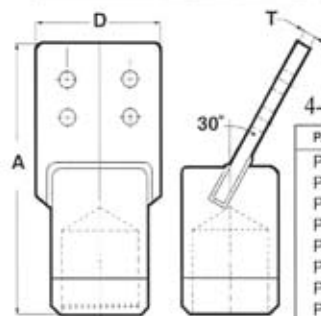

## 4-Hole Terminal 30° NEMA Pad

PART NO.	SIZE NPS	A	D	T
PLK1863D16A	1	9.517	3.00	.375
PLK1863D16B	1	9.517	4.00	.375
PLK1863D24A	1-1/2	9.747	3.00	.500
PLK1863D24B	1-1/2	9.747	4.00	.500
PLK1863D32A	2	11.042	3.00	.500
PLK1863D32B	2	11.042	4.00	.500
PLK1863D40A	2-1/2	11.259	3.00	.625
PLK1863D40B	2-1/2	11.259	4.00	.625
PLK1863D48A	3	11.555	3.00	.750
PLK1863D48B	3	11.555	4.00	.750
PLK1863D56A	3-1/2	11.705	3.00	.750
PLK1863D56B	3-1/2	11.705	4.00	.750
PLK1863D64A	4	11.860	3.00	.750
PLK1863D64B	4	11.860	4.00	.750
PLK1863D80A	5	13.675	3.00	1.000
PLK1863D80B	5	13.675	4.00	1.000

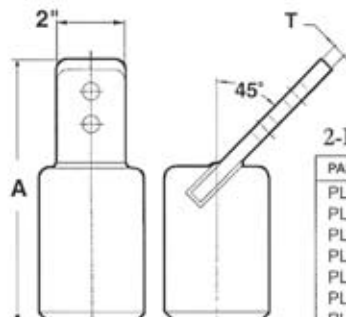

## 2-Hole Terminal 45° NEMA Pad

PART NO.	SIZE NPS	A	T
PLK1865D16	1	8.43	.375
PLK1865D24	1-1/2	8.70	.500
PLK1865D32	2	10.00	.500
PLK1865D40	2-1/2	10.23	.625
PLK1865D48	3	10.56	.750
PLK1865D56	3-1/2	10.71	.750
PLK1865D64	4	10.86	.750
PLK1865D80	5	12.70	1.000



# BUS CONNECTORS

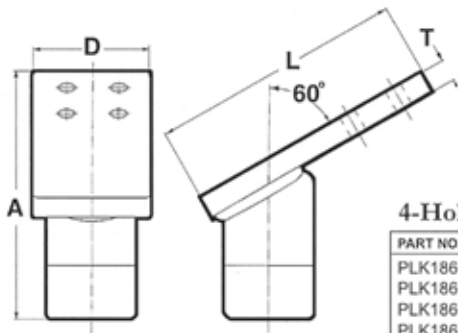

4-Hole Terminal 60° NEMA Pad

PART NO.	SIZE NPS	A	D	L	T
PLK1866D16A	1	6.259	3.00	7.100	.375
PLK1866D16B	1	6.259	4.00	7.100	.375
PLK1866D24A	1-1/2	6.758	3.00	7.815	.500
PLK1866D24B	1-1/2	6.758	4.00	7.815	.500
PLK1866D32A	2	8.109	3.00	8.550	.500
PLK1866D32B	2	8.109	4.00	8.550	.500
PLK1866D40A	2-1/2	8.951	3.00	9.700	.625
PLK1866D40B	2-1/2	8.951	4.00	9.700	.625
PLK1866D48A	3	9.518	3.00	10.625	.750
PLK1866D48B	3	9.518	4.00	10.625	.750
PLK1866D56A	3-1/2	10.009	3.00	11.550	.750
PLK1866D56B	3-1/2	10.009	4.00	11.550	.750
PLK1866D64A	4	10.418	3.00	12.300	.750
PLK1866D64B	4	10.418	4.00	12.300	.750
PLK1866D80A	5	12.701	3.00	13.300	1.000
PLK1866D80B	5	12.701	4.00	13.300	1.000

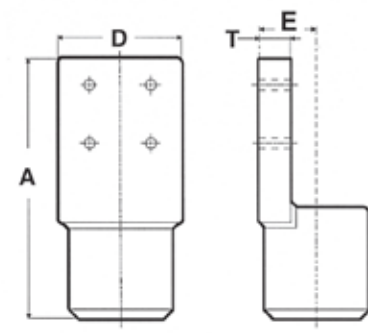

4-Hole Terminal, Side Formed NEMA Pad

PART NO.	SIZE NPS	A	D	E	T
PLK1880D16A	1	10.00	3.00	1.07	.375
PLK1880D16B	1	10.00	4.00	1.07	.375
PLK1880D24A	1-1/2	10.25	3.00	1.32	.500
PLK1880D24B	1-1/2	10.25	4.00	1.32	.500
PLK1880D32A	2	11.20	3.00	1.57	.500
PLK1880D32B	2	11.20	4.00	1.57	.500
PLK1880D40A	2-1/2	11.32	3.00	1.95	.625
PLK1880D40B	2-1/2	11.32	4.00	1.95	.625
PLK1880D48A	3	11.45	3.00	2.26	.750
PLK1880D48B	3	11.45	4.00	2.26	.750
PLK1880D56A	3-1/2	11.75	3.00	2.57	.750
PLK1880D56B	3-1/2	11.75	4.00	2.57	.750
PLK1880D64A	4	12.00	3.00	2.82	.750
PLK1880D64B	4	12.00	4.00	2.82	.750
PLK1880D80A	5	14.00	3.00	3.32	1.000
PLK1880D80B	5	14.00	4.00	3.32	1.000
PLK1880D96A	6	15.00	3.00	4.38	1.000
PLK1880D96B	6	15.00	4.00	4.38	1.000

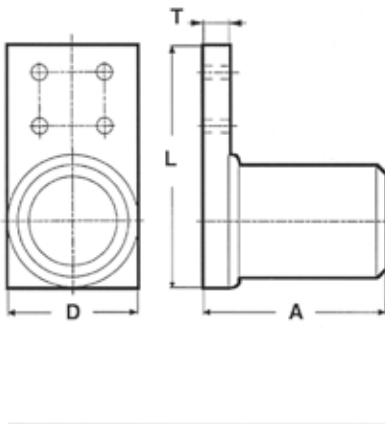

4-Hole Terminal 90° NEMA Pad

PART NO.	SIZE NPS	A	D	L	T
PLK1870D16A	1	3.57	3.00	7.10	.375
PLK1870D16B	1	3.57	4.00	7.10	.375
PLK1870D24A	1-1/2	3.82	3.00	7.81	.500
PLK1870D24B	1-1/2	3.82	4.00	7.81	.500
PLK1870D32A	2	5.02	3.00	8.55	.500
PLK1870D32B	2	5.02	4.00	8.55	.500
PLK1870D40A	2-1/2	5.40	3.00	9.70	.625
PLK1870D40B	2-1/2	5.40	4.00	9.70	.625
PLK1870D48A	3	5.77	3.00	10.62	.750
PLK1870D48B	3	5.77	4.00	10.62	.750
PLK1870D56A	3-1/2	6.07	3.00	11.55	.750
PLK1870D56B	3-1/2	6.07	4.00	11.55	.750
PLK1870D64A	4	6.32	3.00	12.30	.750
PLK1870D64B	4	6.32	4.00	12.30	.750
PLK1870D80A	5	8.32	3.00	13.30	1.000
PLK1870D80B	5	8.32	4.00	13.30	1.000
PLK1870D96A	6	9.32	3.00	14.80	1.000
PLK1870D96B	6	9.32	4.00	14.80	1.000

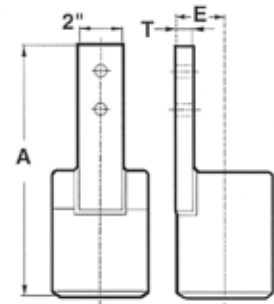

2-Hole Terminal Side Formed NEMA Pad

PART NO.	SIZE NPS	A	E	T
PLK1885D16	1	10.00	1.07	.375
PLK1885D24	1-1/2	10.25	1.32	.500
PLK1885D32	2	11.20	1.57	.500
PLK1885D40	2-1/2	11.32	1.95	.625
PLK1885D48	3	11.45	2.26	.750
PLK1885D56	3-1/2	11.75	2.57	.750
PLK1885D64	4	12.00	2.82	.750
PLK1885D80	5	14.00	3.32	1.000

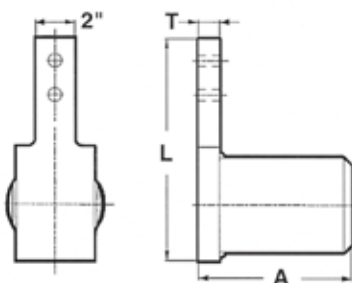

2-Hole Terminal 90° NEMA Pad

PART NO.	SIZE NPS	A	L	T
PLK1875D16	1	3.57	7.10	.375
PLK1875D24	1-1/2	3.82	8.55	.500
PLK1875D32	2	5.02	8.55	.500
PLK1875D40	2-1/2	5.40	9.70	.625
PLK1875D48	3	5.77	12.30	.750
PLK1875D56	3-1/2	6.07	12.30	.750
PLK1875D64	4	6.32	12.30	.750
PLK1875D80	5	8.32	13.30	1.000

# BUS CONNECTORS

## Slip / Fixed Bus Supports

Our new Permanent Mold Bus Support is EHV rated up to 500 kV  
(for more information on Bolt Circle Patterns, see page 3)

PART NO.	NPS SIZE	BOLT CIRCLE	H	L	W	BOLT SIZE
PLK2230D16E12	1	3 & 5	2	9	5 1/2	3/8
PLK2230D24E12	1 1/2	3 & 5	2 1/2	9	5 1/2	3/8
PLK2230D32E12	2	3 & 5	2 3/4	10	6 1/2	1/2
PLK2230D40E12	2 1/2	3 & 5	3 1/8	10	6 1/2	1/2
PLK2230D48E12	3	3 & 5	3 5/8	10	6 1/2	1/2
PLK2230D56E12	3 1/2	3 & 5	4	10	6 1/2	5/8
PLK2230D64E12	4	3 & 5	4 1/2	10	6 1/2	5/8
PLK3230D64E123 (EHV)	4	3, 5 & 7	4 1/2	14	9 3/8	5/8
PLK2230D80E23	5	5 & 7	5	11 1/2	7 1/2	5/8
PLK3230D80E23 (EHV)	5	6 & 7	5	14	9 3/8	5/8
PLK2230D96E23	6	7 & 7	5 1/2	11 1/2	7 1/2	5/8
PLK3230D96E23 (EHV)	7	8 & 7	5 1/2	14	9 3/8	5/8

PLK2230

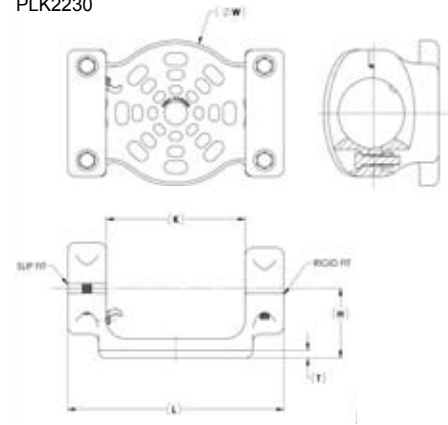

PLK3230

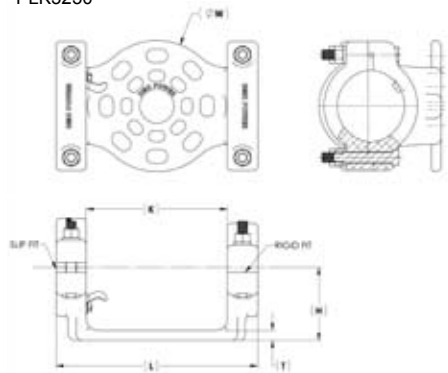

### BUS SUPPORT/EXPANSION EXAMPLE:

**PLK2230 D 24 - E12**

↑ Slip/Rigid Fit Bus Support      ↑ 1 1/2" Bus Run      ↑ 3" & 5" Bolt Circle

## Slip / Rigid Horizontal Bus Support Assembly

(for more information on Bolt Circle Patterns, see page 3)

PART NO.	FIGURE NUMBER	SIZE NPS	BOLT CIRCLE	H	L	T	W
PLK2210D16E1	2	1	3 (ONLY)	2	5.50	1/2	3.00
PLK2210D16E2	1	1	5	2 1/4	8.50	1/2	3.00
PLK2210D24E12	2	1 1/2	3 & 5	2 1/2	7.75	3/4	3.50
PLK2210D32E12	2	2	3 & 5	2 1/2	7.75	3/4	4.00
PLK2210D40E12	2	2 1/2	3 & 5	2 3/4	7.75	3/4	4.75
PLK3210D48E12 §	2	3	3 & 5	3 5/8	7.75	3/4	5.50
PLK2210D48E3	1	3	7	3 5/8	9.25	1/2	6.00
PLK3210D56E12 §	2	3 1/2	3 & 5	4	7.75	3/4	6.50
PLK2210D56E3	1	3 1/2	7	4	9.25	1/2	6.00
PLK3210D64E12 §	2	4	3 & 5	4 1/2	7.75	3/4	6.50
PLK2210D64E3	1	4	7	4 1/2	9.25	1/2	7.00
PLK2210D80E1	1	5	3	5	6.50	1/2	8.00
PLK3210D80E23 §	2	5	5 & 7	5	10.50	3/4	7.50
PLK3210D96E23 §	2	6	5 & 7	5 1/2	10.50	3/4	9.00

§ This part number is suitable for up to 500 kV.

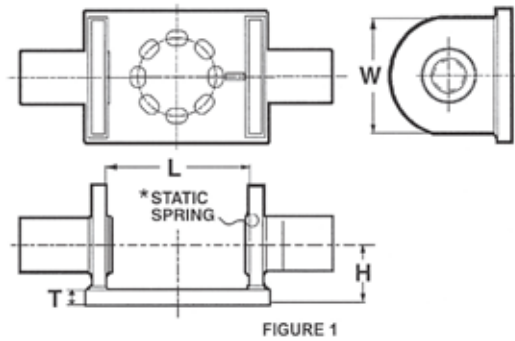

FIGURE 1

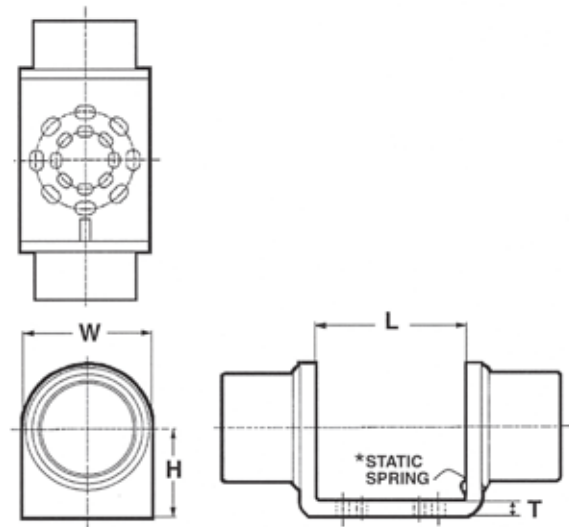
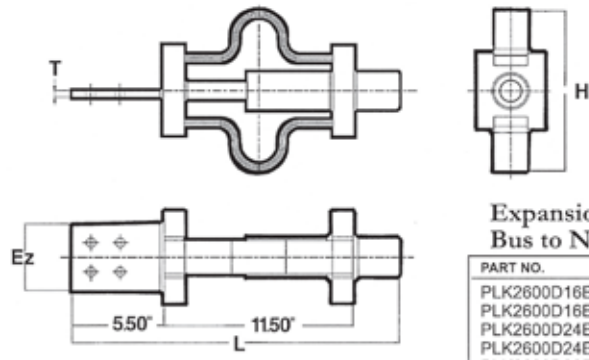

FIGURE 2 (Casted Frame)



# BUS CONNECTORS



Expansion Joint with Guide  
Bus to NEMA Pad

PART NO.	SIZE NPS	H	L	T
PLK2600D16E1	1	11.38	20.03	3/8
PLK2600D16E2	1	11.38	20.03	3/8
PLK2600D24E1	1-1/2	11.57	20.03	1/2
PLK2600D24E2	1-1/2	11.57	20.03	1/2
PLK2600D32E1	2	11.83	20.03	1/2
PLK2600D32E2	2	11.83	20.03	1/2
PLK2600D40E1	2-1/2	13.01	20.03	5/8
PLK2600D40E2	2-1/2	13.01	20.03	5/8
PLK2600D48E1	3	13.20	20.03	3/4
PLK2600D48E2	3	13.20	20.03	3/4
PLK2600D48E3	3	13.20	20.03	3/4
PLK2600D56E1	3-1/2	14.52	20.03	3/4
PLK2600D56E2	3-1/2	14.52	20.03	3/4
PLK2600D56E3	3-1/2	14.52	20.03	3/4
PLK2600D64E1	4	14.71	20.03	3/4
PLK2600D64E2	4	14.71	20.03	3/4
PLK2600D64E3	4	14.71	20.03	3/4
PLK2600D64E4	4	14.71	20.03	3/4
PLK2600D80E1	5	16.17	23.03	1
PLK2600D80E2	5	16.17	23.03	1
PLK2600D80E3	5	16.17	23.03	1
PLK2600D80E4	5	16.17	23.03	1
PLK2600D96E1	6	17.67	24.03	1
PLK2600D96E2	6	17.67	24.03	1
PLK2600D96E3	6	17.67	24.03	1
PLK2600D96E4	6	17.67	24.03	1

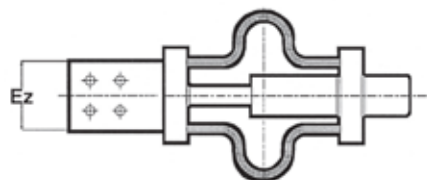

ROTATED PAD OPTION

Option - Add -90 to the end of the part number for the pad to be rotated 90 degrees.

EXAMPLE: PLK2600D64E1-90

Ex DIM	E1	E2	E3	E4
	4.00	3.00	5.00	6.00

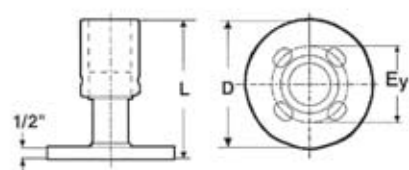

Vertical Bus Support Assembly

PART NO.	SIZE NPS	D	L
PLK2260D16E1	1	5.00	6-1/4
PLK2260D16E2	1	6.50	6-1/4
PLK2260D24E1	1-1/2	5.00	6-1/4
PLK2260D24E2	1-1/2	6.50	6-1/4
PLK2260D32E1	2	5.00	6-1/4
PLK2260D32E2	2	6.50	6-1/4
PLK2260D40E1	2-1/2	5.00	6-1/4
PLK2260D40E2	2-1/2	6.50	6-1/2
PLK2260D48E1	3	5.00	7-1/2
PLK2260D48E2	3	6.50	7-1/2
PLK2260D48E3	3	9.00	7-1/2
PLK2260D56E1	3-1/2	5.00	7-1/2
PLK2260D56E2	3-1/2	6.50	7-1/2
PLK2260D56E3	3-1/2	9.00	7-1/2
PLK2260D64E1	4	5.00	7-1/2
PLK2260D64E2	4	6.50	7-1/2
PLK2260D64E3	4	9.00	7-1/2
PLK2260D80E1	5	5.00	8-1/2
PLK2260D80E2	5	6.50	8-1/2
PLK2260D80E3	5	9.00	8-1/2

Ey DIM	E1	E2	E3
	3.00	5.00	7.00

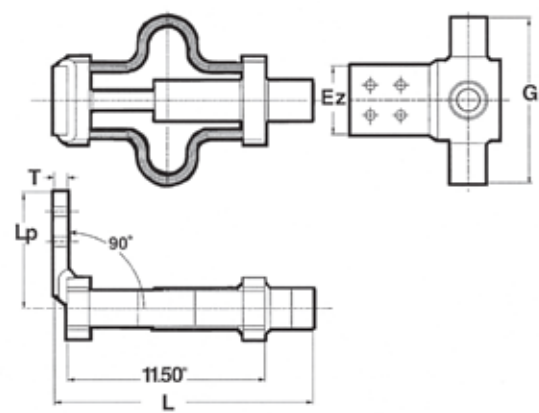

Expansion Joint with Guide - Bus to 90° NEMA Pad

PART NO.	SIZE NPS	G	L	Lp	T
PLK2601D16E1	1	10.384	14.905	6.50	3/8
PLK2601D16E2	1	10.384	14.905	6.50	3/8
PLK2601D24E1	1-1/2	11.076	15.030	6.50	1/2
PLK2601D24E2	1-1/2	11.076	15.030	6.50	1/2
PLK2601D32E1	2	11.832	15.030	7.00	1/2
PLK2601D32E2	2	11.832	15.030	7.00	1/2
PLK2601D40E1	2-1/2	12.390	15.155	7.50	5/8
PLK2601D40E2	2-1/2	12.390	15.155	7.50	5/8
PLK2601D40E3	2-1/2	12.390	15.155	7.50	5/8
PLK2601D48E1	3	13.207	15.280	7.50	3/4
PLK2601D48E2	3	13.207	15.280	7.50	3/4
PLK2601D48E3	3	13.207	15.280	7.50	3/4

PART NO.	G	L	Lp	T	
PLK2601D56E1	3-1/2	14.024	15.280	8.00	3/4
PLK2601D56E2	3-1/2	14.024	15.280	8.00	3/4
PLK2601D56E3	3-1/2	14.024	15.280	8.00	3/4
PLK2601D64E1	4	14.716	15.280	8.00	3/4
PLK2601D64E2	4	14.716	15.280	8.00	3/4
PLK2601D64E3	4	14.716	15.280	8.00	3/4
PLK2601D64E4	4	14.716	15.280	8.00	3/4
PLK2601D80E1	5	16.170	18.530	9.00	1
PLK2601D80E2	5	16.170	18.530	9.00	1
PLK2601D80E3	5	16.170	18.530	9.00	1
PLK2601D80E4	5	16.170	18.530	9.00	1

Ex DIM	E1	E2	E3	E4
	4.00	3.00	5.00	6.00

# BUS CONNECTORS

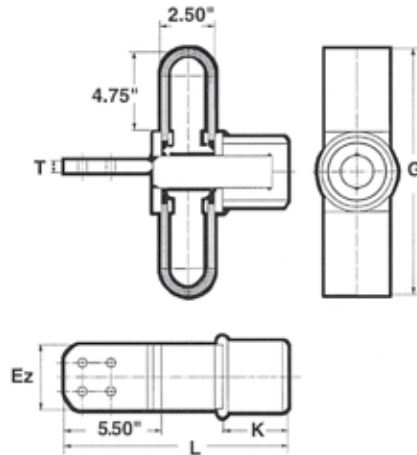

Expansion Joint with Guide  
Bus to NEMA Pad - Reduced Length

PART NO.	SIZE NPS	Ez	G(MAX)	K	L	T
PLK2602D16E1	1	4.00	13.384	3.75	11.634	.375
PLK2602D16E2	1	3.00	13.384	3.75	11.634	.375
PLK2602D24E1	1-1/2	4.00	14.076	3.80	12.126	.500
PLK2602D24E2	1-1/2	3.00	14.076	3.80	12.126	.500
PLK2602D32E1	2	4.00	14.832	3.85	12.682	.500
PLK2602D32E2	2	3.00	14.832	3.85	12.682	.500
PLK2602D40E1	2-1/2	4.00	14.640	4.10	12.740	.625
PLK2602D40E2	2-1/2	3.00	14.640	4.10	12.740	.625
PLK2602D48E1	3	4.00	15.332	4.20	13.032	.750
PLK2602D48E2	3	3.00	15.332	4.20	13.032	.750
PLK2602D56E1	3-1/2	4.00	15.524	4.40	13.424	.750
PLK2602D56E2	3-1/2	3.00	15.524	4.40	13.424	.750
PLK2602D64E1	4	4.00	16.716	4.50	14.216	.750
PLK2602D64E2	4	3.00	16.716	4.50	14.216	.750
PLK2602D80E1	5	4.00	17.164	7.50	17.664	1.000
PLK2602D80E2	5	3.00	17.164	7.50	17.664	1.000

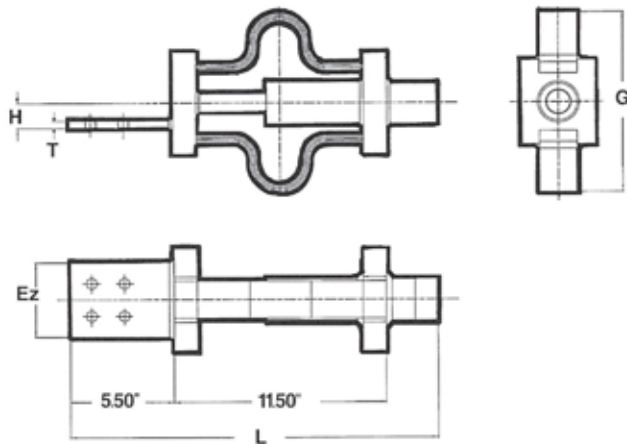

Expansion Joint with Guide  
Bus to Side Formed NEMA Pad

PART NO.	SIZE NPS	G	H	L	T
PLK2610D16E1	1	10.384	1.075	20.030	3/8
PLK2610D16E2	1	10.384	1.075	20.030	3/8
PLK2610D24E1	1-1/2	11.076	1.325	20.030	1/2
PLK2610D24E2	1-1/2	11.076	1.325	20.030	1/2
PLK2610D32E1	2	11.832	1.575	20.030	1/2
PLK2610D32E2	2	11.832	1.575	20.030	1/2
PLK2610D40E1	2-1/2	12.390	1.950	20.030	5/8
PLK2610D40E2	2-1/2	12.390	1.950	20.030	5/8
PLK2610D40E3	2-1/2	12.390	1.950	20.030	5/8
PLK2610D48E1	3	13.207	2.262	20.030	3/4
PLK2610D48E2	3	13.207	2.262	20.030	3/4
PLK2610D48E3	3	13.207	2.262	20.030	3/4
PLK2610D56E1	3-1/2	14.024	2.575	20.030	3/4
PLK2610D56E2	3-1/2	14.024	2.575	20.030	3/4
PLK2610D56E3	3-1/2	14.024	2.575	20.030	3/4
PLK2610D56E4	3-1/2	14.024	2.575	20.030	3/4
PLK2610D64E1	4	14.716	2.875	20.030	3/4
PLK2610D64E2	4	14.716	2.875	20.030	3/4
PLK2610D64E3	4	14.716	2.875	20.030	3/4
PLK2610D64E4	4	14.716	2.875	20.030	3/4
PLK2610D80E1	5	16.170	3.325	20.030	1
PLK2610D80E2	5	16.170	3.325	20.030	1
PLK2610D80E3	5	16.170	3.325	20.030	1
PLK2610D80E4	5	16.170	3.325	20.030	1

Ez DIM	E1	E2	E3	E4
	4.00	3.00	5.00	6.00

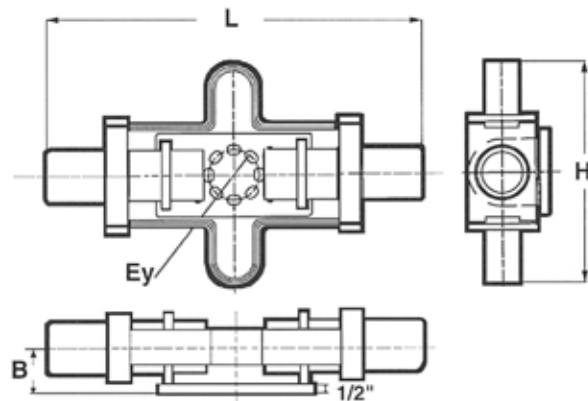

FIGURE 1

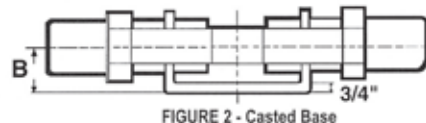

FIGURE 2 - Casted Base

Expansion Bus Support

PART NO.	SIZE NPS	FIGURE	B	H	L
PLK2700D32E12	2	2	2-3/4	12.732	22.75
PLK2700D40E12	2-1/2	2	3-1/8	13.540	20.75
PLK2700D48E12	3	2	3-5/8	14.732	20.75
PLK2700D48E3	3	1	3-5/8	14.732	22.19
PLK2700D56E12	3-1/2	2	4	14.924	20.75
PLK2700D56E3	3-1/2	1	4	14.924	22.19
PLK2700D64E12	4	2	4-1/2	16.116	20.75
PLK2700D64E3	4	1	4-1/2	16.116	22.19
PLK2700D80E1	5	1	5	17.564	28.06
PLK2700D80E23	5	2	5	17.564	30.19
PLK2700D96E23	6	2	5-1/2	18.500	32.19

Ey BOLT CIRCLE	E1	E3	E12	E23
	3	7	3&5	5&7

# BUS CONNECTORS

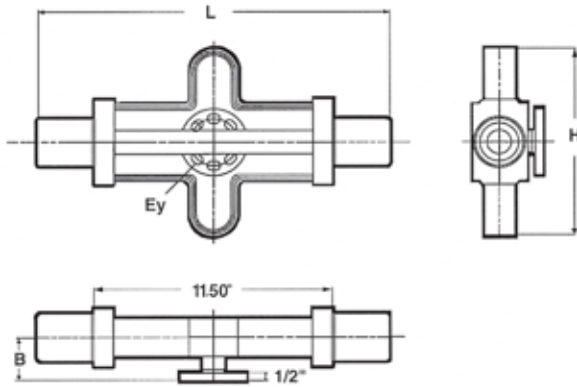

Expansion Bus Support  
Reduced Weight

PART NO.	SIZE NPS	H	L	B
PLK2701D32Ey	2	11.832	18.85	2-3/4
PLK2701D40Ey	2-1/2	12.390	19.35	3-1/8
PLK2701D48Ey	3	13.207	19.55	3-5/8
PLK2701D56Ey	3-1/2	14.024	19.95	4
PLK2701D64Ey	4	14.716	20.15	4-1/2
PLK2701D80Ey	5	16.170	26.15	5

Eye DIM	E1	E2	E3
	3.00	5.00	7.00

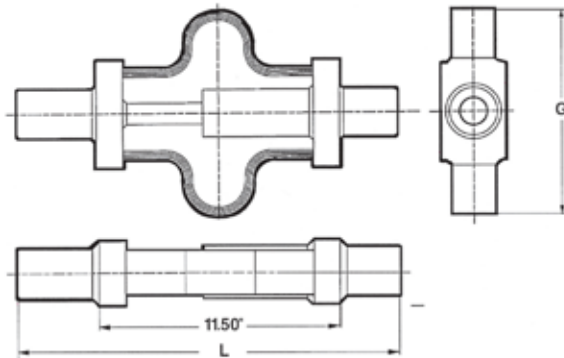

Expansion Joint with Guide  
Bus to Bus

PART NO.	SIZE NPS	G	L
PLK2810D16	1	10.384	18.28
PLK2810D24	1-1/2	11.076	18.33
PLK2810D32	2	11.832	18.38
PLK2810D40	2-1/2	12.390	18.63
PLK2810D48	3	13.207	18.73
PLK2810D56	3-1/2	14.024	18.93
PLK2810D64	4	14.716	19.03
PLK2810D80	5	16.170	25.03
PLK2810D96	6	17.670	27.03

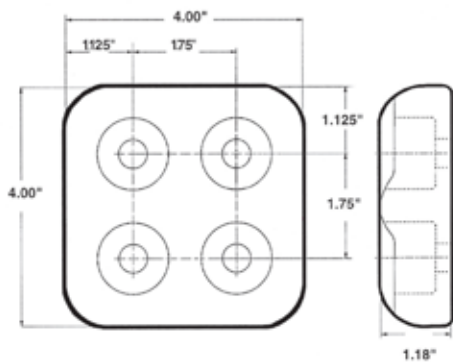

Corona Bolt Shield Pad

PART NO.
PLK8000D4

**YOUR PART HERE**

**We Make Specials**

- Need something different? Don't see the configuration you need? Let us make it for you.
- Most of our standard connectors have come from customer inquiries and requests.
- We offer complete engineering, R&D testing in NADCAP approved labs and manufacturing at our ISO 9001:2008 facilities

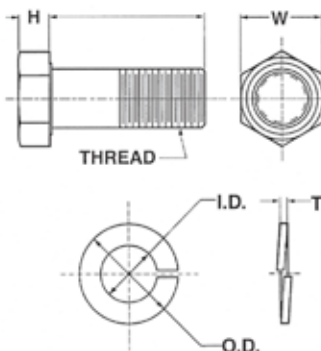

Bus Support Bolt Package

BOLT PKG PART NO.	H	L	W	THREAD	ID	OD	T
PLK8010C0612	15/64	1.25	9/16	3/8-16UNC-2A	.318	.688	.094
PLK8010C0615	15/64	1.50	9/16	3/8-16UNC-2A	.318	.688	.094
PLK8010C0620	15/64	2.00	9/16	3/8-16UNC-2A	.318	.688	.094
PLK8010C0815	5/16	1.50	3/4	1/2-13UNC-2A	.509	.879	.125
PLK8010C0820	5/16	2.00	3/4	1/2-13UNC-2A	.509	.879	.125
PLK8010C0825	5/16	2.50	3/4	1/2-13UNC-2A	.509	.879	.125
PLK8010C1015	25/64	1.50	15/16	5/8-11UNC-2A	.636	1.086	.156
PLK8010C1020	25/64	2.00	15/16	5/8-11UNC-2A	.636	1.086	.156
PLK8010C1025	25/64	2.50	15/16	5/8-11UNC-2A	.636	1.086	.156
PLK8010C1215	15/32	1.50	1 <sup>1/8</sup>	3/4-10UNC-2A	.766	1.265	.188
PLK8010C1220	15/32	2.00	1 <sup>1/8</sup>	3/4-10UNC-2A	.766	1.265	.188
PLK8010C1225	15/32	2.50	1 <sup>1/8</sup>	3/4-10UNC-2A	.766	1.265	.188

Bolts and washers can be supplied for Bus Supports.

You'll need to order them as a separate line item using the part numbers listed above.

Each Bolt Package consists of four bolts and four split washers made from Stainless Steel (300 series CRES).

Recommended "Standard" Bolt Packages for Bus Support Circles

BOLT PACKAGE PART NUMBER	BUS SUPPORT BOLT CIRCLE
PLK8010C0815	3"
PLK8010C1015	5"
PLK8010C1215	7"



# BUS EHV CONNECTORS

- All parts tested Corona free for use at and above 500 kV
- Corrosion-resistant material machined to a high quality surface finish, designed-in shielding rings, and generous mass & radii for high ampacity and voltage
- Manufactured to the highest standards to preserve quality and connector performance
- Swaging reduces installation time, maintenance and cost

**PLK3039**  
Offset Splice

**PLK3160**  
Ground Stud

**PLK3162** Double Grounding Stud  
**PLK3166** Split Main Run

**PLK3200**  
Bus Support (slip)

**PLK3210**  
Bus Support (fixed/slip)

**PLK3361**  
End Cap (ball)

**PLK3360** End Cap (ring)

**PLK3401**  
Large Radius Elbow

**PLK3400**  
Elbow

**PLK3600**  
Expansion (bus to pad)

**PLK3698**  
Expansion Terminal - Partial Corona Ring

**PLK3700**  
Expansion (with support)

**PLK3701** Reduced Expansion  
**PLK3702** 2 Corona Ring Expansion

**PLK3810**  
Expansion (bus to bus)

**PLK8000**  
Bolt Shield Pad

**PLK8000D4**  
4 hole pad

**PLK8000D6**  
6 hole pad

# BUS VOLTAGE RATINGS

- Voltage ratings are dependent upon connector configuration and application
- Bolt shields are required for all terminal EHV pads
- Voltage based on testing completed in lab setting, non-tested connectors rated by similarity

	Part Number	Description	Voltage Rating (kV) by Bus Size				
			3"	3.5"	4"	5"	6"
COUPLERS	PLK1000	Splice	500	500	500	765	765
	PLK1001	Long Splice	500	500	500	765	765
	PLK1010	Reducer	500	500	500	500	500
	PLK1099	Reducer, From 8" (Weld)	500	500	500	500	500
ELBOWS	PLK1400	Elbow	230	230	230	230	230
	PLK3400	<b>EHV Elbow - Corona Ring</b>	<b>500</b>	<b>500</b>	<b>500</b>	<b>500</b>	<b>500</b>
	PLK3401	<b>EHV Elbow - Large Radius</b>	<b>500</b>	<b>500</b>	<b>500</b>	<b>765</b>	<b>765</b>
GROUNDING	PLK1160	Grounding Stud	230	230	230	230	230
	PLK3160	<b>EHV Grounding Stud</b>	<b>500</b>	<b>500</b>	<b>500</b>	<b>500</b>	<b>500</b>
	PLK1161	Grounding Stirrup	230	230	230	230	230
	PLK3162	<b>EHV Double Grounding Stud</b>	<b>500</b>	<b>500</b>	<b>500</b>	<b>500</b>	<b>500</b>
END CAPS	PLK3166	<b>EHV Grounding Stud (Split Run)</b>	<b>500</b>	<b>500</b>	<b>500</b>	<b>500</b>	<b>500</b>
	PLK1350	End Cap	230	230	230	230	230
	PLK1360	Rounded End Cap	230	230	230	230	230
	PLK3360	<b>EHV End Cap - Ring</b>	<b>500</b>	<b>500</b>	<b>500</b>	<b>500</b>	<b>500</b>
TEE/VEE	PLK3361	<b>EHV End Cap - Ball</b>	<b>500</b>	<b>500</b>	<b>500</b>	<b>500</b>	<b>500</b>
	PLK1100	Tee, 4 Hole Pad Tap	500	500	500	500	500
	PLK5100	Tee, 4 Hole Pad Tap, Split	500	500	500	500	500
	PLK1106	Tee, 6 Hole Pad Tap	500	500	500	500	500
	PLK1120	Tee, Two 4 Hole Pad Taps	500	500	500	500	500
	PLK1150	Tee, Transverse 4 Hole Pad Tap	500	500	500	500	500
	PLK1170	Tee, Two Transverse 4 Hole Pad Taps	500	500	500	500	500
	PLK3039	<b>EHV Offset Splice</b>	<b>500</b>	<b>500</b>	<b>500</b>	<b>500</b>	<b>500</b>
	PLK1500	Tee - Bus to Bus	500	500	500	765	765
	PLK5500	Tee - Bus to Bus, Split	500	500	500	500	500
	PLK1600	A-Frame - Bus to Bus	500	500	500	765	765
	PLK1650	A-Frame (Wide Body) - Bus to Bus	500	500	500	765	765
	PLK1700	Cross - Bus to Bus	500	500	500	765	765
	PLK1701	Cross - Reducer - Bus to Bus	500	500	500	500	500
PLK1702	Cross - Mixed Sizes - Bus to Bus	500	500	500	500	500	
TERMINALS	PLK1850	Centerline NEMA Terminal	345	500	500	500	500
	PLK1856	Centerline NEMA Terminal, 6 Hole	345	500	500	500	500
	PLK1860	NEMA Terminal, 4 Hole Pad, 45°	345	500	500	500	500
	PLK1861	NEMA Terminal, 6 Hole Pad, 45°	345	500	500	500	500
	PLK1863	NEMA Terminal, 4 Hole Pad, 30°	345	500	500	500	500
	PLK1866	NEMA Terminal, 4 Hole Pad, 60°	345	500	500	500	500
	PLK1870	NEMA Terminal, 4 Hole Pad, 90°	230	345	345	345	345
	PLK1873	Triangular NEMA Terminal Assembly, 4 Hole Pad	345	500	500	500	500
	PLK1880	NEMA Terminal, Offset 4 Hole Pad	345	500	500	500	500
	PLK1883	Double NEMA Terminal, 4 Hole Pad	345	500	500	500	500
PLK1886	NEMA Terminal, Offset 6 Hole Pad	345	500	500	500	500	
SUPPORT	PLK2200	Bus Support - Slip	345	345	345	345	345
	PLK3200	<b>EHV Bus Support - Slip</b>	<b>500</b>	<b>500</b>	<b>500</b>	<b>500</b>	<b>500</b>
	PLK2210	Bus Support - Rigid or Slip	345	345	345	345	345
	PLK3210	<b>EHV Bus Support - Rigid or Slip</b>	<b>500</b>	<b>500</b>	<b>500</b>	<b>500</b>	<b>500</b>
	PLK3212	<b>EHV Bus Support - Rigid</b>	<b>500</b>	<b>500</b>	<b>500</b>	<b>500</b>	<b>500</b>
	PLK2230	Bus Support - Clamp	230	230	230	230	230
	PLK2260	Vertical Bus Support	345	345	345	345	345
EXPANSION	PLK3501	<b>EHV Bus Support Tee</b>	<b>500</b>	<b>500</b>	<b>500</b>	<b>500</b>	<b>500</b>
	PLK2600	Expansion Terminal - Bus to Pad	230	230	230	230	230
	PLK3600	<b>EHV Expansion Terminal - Bus to Pad</b>	<b>500</b>	<b>500</b>	<b>500</b>	<b>500</b>	<b>500</b>
	PLK2602	Expansion Terminal - Bus to Pad Reduced	230	230	230	230	230
	PLK2610	Expansion Terminal - Bus to Offset Pad	230	230	230	230	230
	PLK2631	Expansion Terminal - Bus to Pad (Cable)	345	345	345	345	345
	PLK3698	<b>EHV Expansion Terminal - Partial Corona Ring</b>	<b>500</b>	<b>500</b>	<b>500</b>	<b>500</b>	<b>500</b>
	PLK3699	<b>EHV Expansion Terminal - Special</b>	<b>500</b>	<b>500</b>	<b>500</b>	<b>500</b>	<b>500</b>
	PLK2700	Expansion Support - Bus to Bus	230	230	230	230	230
	PLK3700	<b>EHV Expansion Bus Support - Bus to Bus</b>	<b>500</b>	<b>500</b>	<b>500</b>	<b>500</b>	<b>500</b>
	PLK2701	Expansion Support - Bus to Bus Reduced	230	230	230	230	230
	PLK3701	<b>EHV Expansion Bus Support - Bus to Bus</b>	<b>500</b>	<b>500</b>	<b>500</b>	<b>500</b>	<b>500</b>
	PLK3702	<b>EHV Expansion Bus Support - Bus to Bus - 2 Corona Rings</b>	<b>500</b>	<b>500</b>	<b>500</b>	<b>500</b>	<b>500</b>
	PLK2810	Expansion Connector - Bus to Bus	230	230	230	230	230
PLK3810	<b>EHV Expansion Connector - Bus to Bus - 2 Corona Rings</b>	<b>500</b>	<b>500</b>	<b>500</b>	<b>500</b>	<b>500</b>	
PLK3910	<b>EHV Clamp On Corona Rings, Dual</b>	<b>500</b>	<b>500</b>	<b>500</b>	<b>500</b>	<b>500</b>	
BOLT SHIELDS	PLK8000D4	Corona Bolt Shield, 4 Hole Pad	500	500	500	500	500
	PLK8000D6	Corona Bolt Shield, 6 Hole Pad	500	500	500	500	500

# BUS TO CABLE CONNECTORS

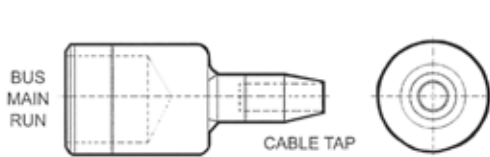

## CL400 - Coupler

Tubing Main Run to Cable Tap

Sizes Available:

MAIN RUN: Tube Sizes 1" to 6" NPS  
TAP: Cable Sizes 6 AWG to 2500 MCM

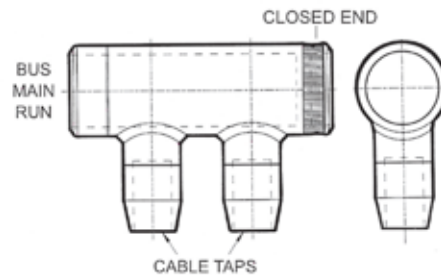

## CL429 - Twin Cable Taps, One End Closed

Tubing Main Run to Cable Tap

Sizes Available:

MAIN RUN: Tube Sizes 1" to 6" NPS  
TAP: Cable Sizes 6 AWG to 2500 MCM

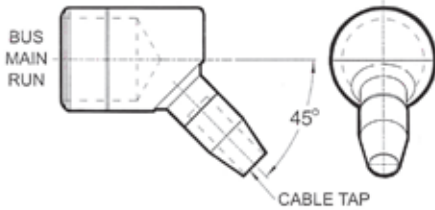

## CL404 - Angle Coupler, 45°

Tubing Main Run to Cable Tap

Sizes Available:

MAIN RUN: Tube Sizes 1" to 6" NPS  
TAP: Cable Sizes 6 AWG to 2500 MCM

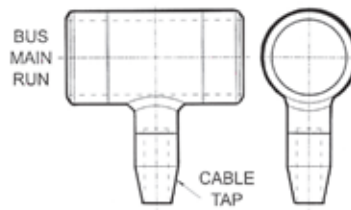

## CL430 - Tee Tap

Tubing Main Run to Cable Tap

Sizes Available:

MAIN RUN: Tube Sizes 1" to 6" NPS  
TAP: Cable Sizes 6 AWG to 2500 MCM

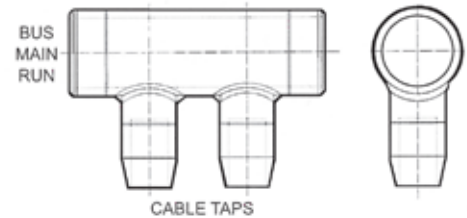

## CL432 - Twin Cable Taps

Tubing Main Run to Cable Tap

Sizes Available:

MAIN RUN: Tube Sizes 1" to 6" NPS  
TAP: Cable Sizes 6 AWG to 2500 MCM

## ORDERING INFORMATION - BUS CONNECTORS

Refer to the Standard Product Dimensions on page 3 for our Bus Size and Bolt Circle Configurations

PLKXXX    D    XX - XXXXX

1 BASIC PART NUMBER

2 MATERIAL CODE (D=Aluminum)

3 BUS RUN SIZE

4 (OPTIONAL) SECOND BUS OR CABLE RUN

### ORDERING EXAMPLE:

<u>PLK1000</u>	<u>D</u>	<u>16</u>
↑		↑
Bus-to-Bus Splice		1" Bus Run



# BUS TOOLING SELECTION CHART

**ONE TOOL IS ALL YOU NEED TO START SWAGING**



Our compact and portable tools (as little as 30 pounds) are hydraulically actuated using a 10,000 psi pump and are capable of producing up to 115 tons of Swaging power! DMC Power will train and certify your entire crew in less than 30 minutes, helping you spend more time installing Bus, Cable and Grounding and less time waiting.

## HEAD ASSEMBLY SIZE

DMC Size	Bus Size	Model 57/58* Power Unit	Model 65 Power Unit	Model 85 Power Unit	Model 115 Power Unit	Swage Dies	Inspection Gauge	Pump Type
16	1"	DLT57PLHA0016	DLT65PLHA0016			DLT56PLDI0016	PLKIG2000-16	DLT06MAPE2001 (Battery) or DLT12MAPE1000 (Electric)
24	1-1/2"	DLT57PLHA0024	DLT65PLHA0024			DLT56PLDI0024	PLKIG2000-24	
32	2"	DLT57PLHA0032	DLT65PLHA0032			DLT56PLDI0032	PLKIG2000-32	
40	2-1/2"	DLT57PLHA0040	DLT65PLHA0040			DLT56PLDI0040	PLKIG2000-40	
48	3"	DLT57PLHA0048	DLT65PLHA0048			DLT56PLDI0048	PLKIG2000-48	
56	3-1/2"		DLT65PLHA0056			DLT65PLDI0056	PLKIG2000-56	
64	4"		DLT65PLHA0064			DLT65PLDI0064	PLKIG2000-64	
80	5"			DLT86PLHA0080		DLT85PLDI0080	PLKIG2000-80	
96	6"				PLT115PLTA0000	PLT115PLDI0096	PLKIG2000-96	PLT115MAPE1000

\*Model 58 Power Unit can also Swage Cable Connectors from 2000 to 2500 MCM

**All tooling is available for PURCHASE, RENTAL and LEASE  
Call 888-SWAGE-NOW or contact your local Territory Manager for more information**

**SAFER**

**FASTER**

**ALL-WEATHER**

**HIGHER QUALITY**

**LOWER TOTAL PROJECT COST**

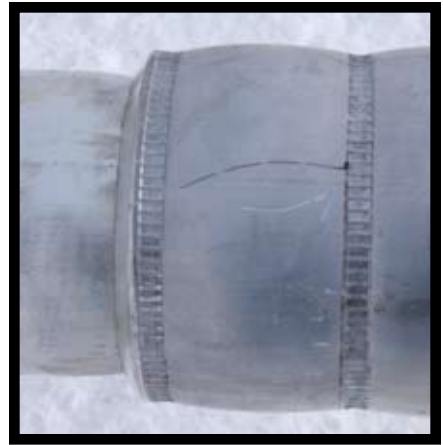

**Sales Offices Located Nationwide  
to Better Serve You**

**DMCPOWER**

Next Generation Power Connections

14502 South Figueroa Street  
Gardena, CA 90248 USA

[www.dmcpower.com](http://www.dmcpower.com)

**888-SWAGE-NOW**

888-792-4366

